

Viga IPS

HECHO EN
MÉXICO
100% MEXICANOS



Figura de acero con terminación curva en forma de S para uso como refuerzo estructural en proyectos de construcción y manufacturas de diversos tipos.



USOS

- Soportes estructurales
- Naves industriales
- Fabricación de largueros y carrocerías
- Fabricación de vagones de ferrocarril

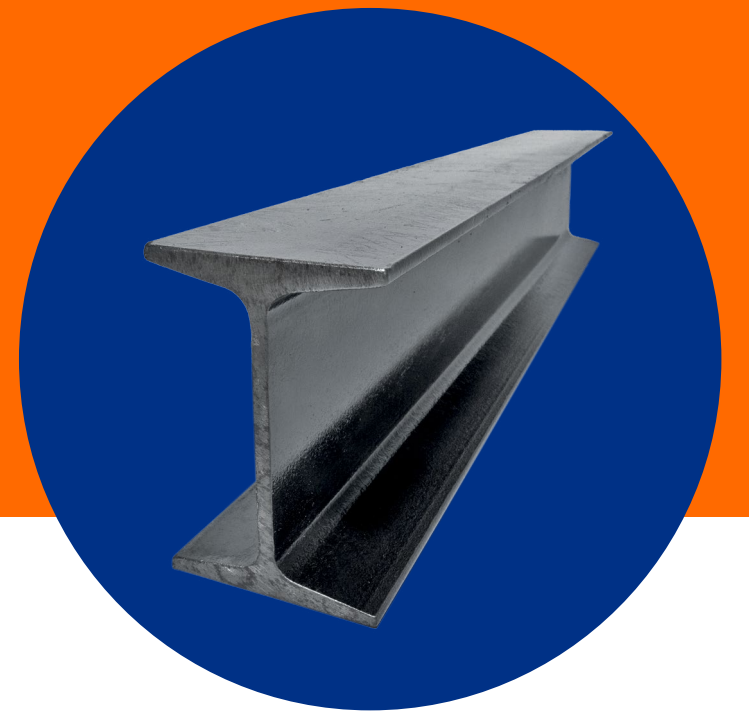
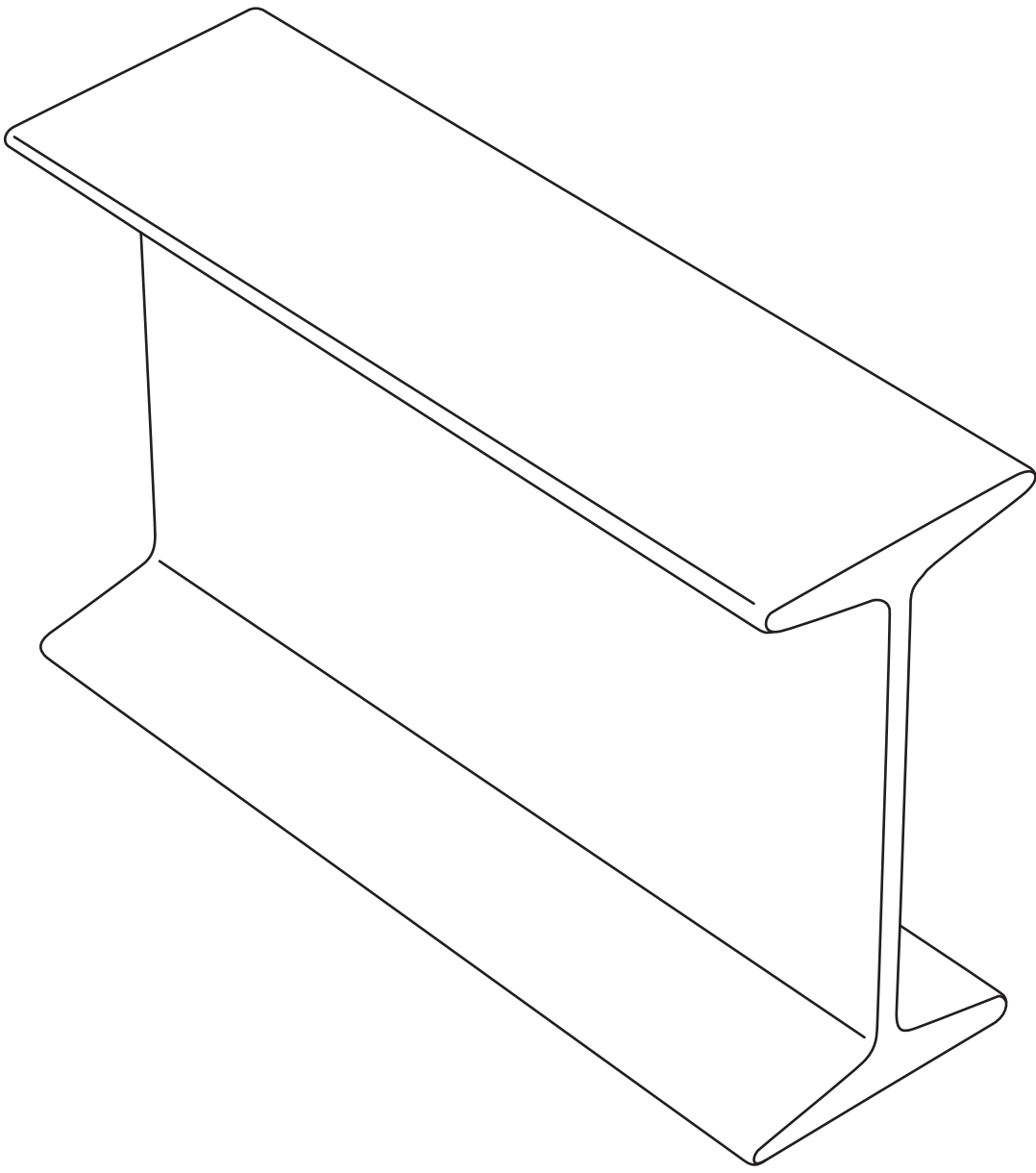
CARACTERÍSTICAS

- Laminados en caliente
- Peraltes desde 3" hasta 8"

VENTAJAS

- Cumplimiento de normas duales
- Alta ductilidad
- Uniformidad en las propiedades del acero

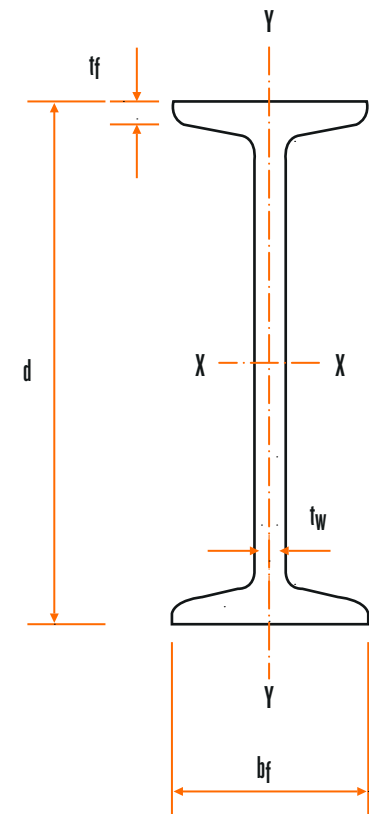

NORMAS DE FABRICACIÓN ASTM A36 | A529-50 | A572-50 | A992

170

Nuestra Inteligencia Industrial® se integra por prácticas sostenibles y responsables que producen el acero más sustentable de Norteamérica y es reconocido por:



Viga IPS

Denominación Peralte x Peso Nominales (in. X lb/ft)	Peso (kg/m)	DIMENSIONES						PROPIEDADES									
		Peralte d (mm)	Espesor del Alma t _w (mm)	Patín		k (mm)	T (mm)	Área A (cm ²)	Eje X-X				Eje Y-Y				J (cm ⁴)
				Ancho b _r (mm)	Espesor t _r (mm)				I (cm ⁴)	S (cm ³)	r (cm)	Z (cm ³)	I (cm ⁴)	S (cm ³)	r (cm)	Z (cm ³)	
3 x 5.7	8.48	76.0	4.32	59.2	6.60	15.9	44.4	10.71	104	27.4	3.12	31.8	18.6	6.28	1.32	10.7	1.80
4 x 7.7	11.5	102	4.90	67.6	7.44	19.0	63.5	14.58	252	49.7	4.17	57.4	31.1	9.21	1.46	15.9	3.05
5 x 10.0	14.9	127	5.44	76.2	8.28	19.0	88.9	18.90	512	80.3	5.21	92.8	49.5	13.0	1.62	22.5	4.75
6 x 12.5	18.6	152	5.89	84.6	9.12	20.6	111	23.61	916	120	6.22	138	74.9	17.7	1.78	30.5	6.95
8 x 18.4	27.4	203	6.88	102	10.8	25.4	152	34.84	2393	236	8.28	270	154	30.2	2.10	52.1	13.9

- Fabricaciones especiales sobre pedido.
- Longitud estándar de 6.10 m y 12.20 m.
- Longitud especial de 15.30 m.

Estándar				
ASTM		A36	A992	A572 Grado 50
Resistencia a la Tensión (kg/mm ²)	Espec			
	min	41	45	45
	max	56	-	-
Resistencia a la Fluencia (kg/mm ²)	min	25	35	35
	max	-	45	-

Calidad Acero	F _y (kg/cm ²)	F _u (kg/cm ²)
ASTM A36	2,530 min.	4,080 - 5,625
ASTM A572-50	3,515 min.	4,570 min.
ASTM A992/572-50	3,515-4,080	4,080 min.
ASTM A36/572-50	3,515 min.	4,080-5,625

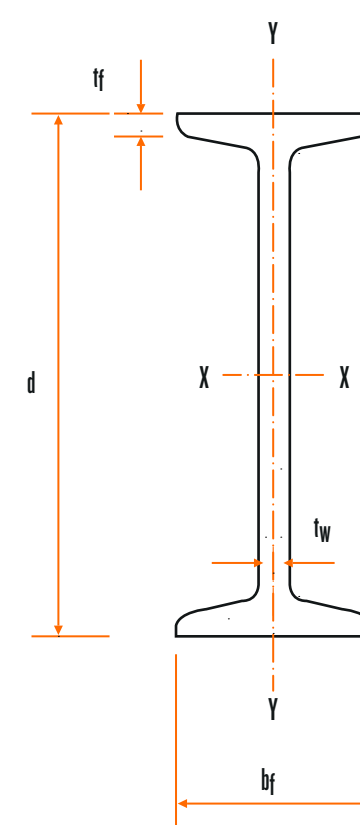

Nuestra Inteligencia Industrial® se integra por prácticas sostenibles y responsables que producen el acero más sustentable de Norteamérica y es reconocido por:

